

ST2



Tesmec ST2 is a 25-30 metric ton-class trencher featuring a 510 HP (375 kW) Tier 4/Stage V engine, or a 536 HP (394 kW) Tier 3 engine, designed to allow the simultaneous trenching and mechanical laying for the deployment of networks in rural environments and rocky grounds

STANDARD FEATURES

Productivity Exploit the productivity of ST2 with R1200, R1200E, R1400, R1400E and R1600 rocksaw attachments, featuring an hydraulic offset of 145 cm (4' 9") from center line on left and right, +/- 15° hydraulic tilt (rotation about horizontal axis) and +/- 27.6° hydraulic pivot (rotation about vertical axis). These are offered as standard with crumbshoe and security kit.

Remote control Experience the radio control system, which enables the operator to control the machine remotely, increasing the safety in site, the visibility on the trenching area and on the trenching tool.

OPTIONAL FEATURES

- Extension for little offset and crossbar for great external offset
- Set of 2 reel holder arms + Round bar : Ø60 mm Lg. 2700 mm
- Working light kit
- Accessories for mechanized laying
- Re.M
- Smart Tracker

STATE OF THE ART TECHNOLOGY

Re.M The remote monitoring system with machine data remote monitoring, fleet location management, troubleshooting information and operating conditions

Smart tracker Automatically collects as-built data while the machine is trenching, avoiding survey stakeout and achieve the complete digitalization of the jobsite

TRENCHING DIMENSIONS

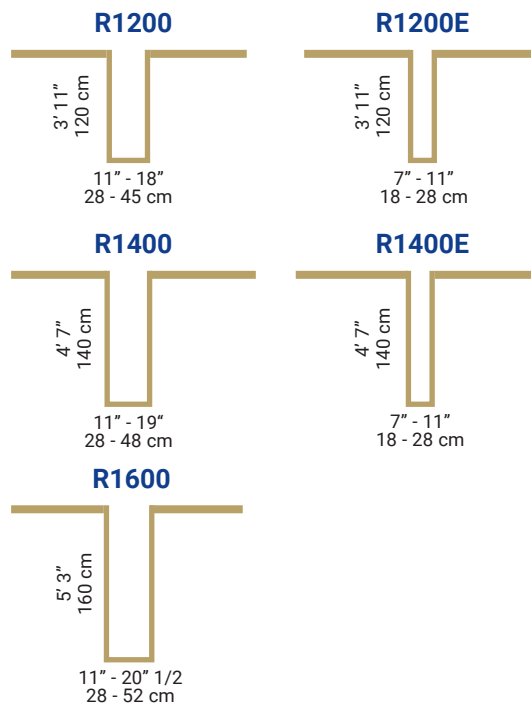

TRANSPORT DIMENSIONS

		METRIC	US
Length	(R1200 - R1200E)	1027 cm	33' 7"
	(R1400 - R1400E)	1066 cm	35'
	(R1600)	1091 cm	35' 8"
Width		250 cm	8' 2"
Height		327 cm	10' 9"
Weight	(R1200)	25.420 Kg	56 200 lbs
	(R1200E)	24.270 Kg	54.800 lbs
	(R1400)	26.630 Kg	58.700 lbs
	(R1400E)	25.060 Kg	57.300 lbs
	(R1600)	29.430 Kg	64.600 lbs
Ground pressure	(R1200)	0.64 kg/cm2	9.3 psi
	(R1200E)	0.61 kg/cm2	8.8 psi
	(R1400)	0.67 kg/cm2	9.7 psi
	(R1400E)	0.63 kg/cm2	9.1 psi
	(R1600)	0.74 kg/cm2	10.5 psi

ENGINE

		METRIC	US
Model and Max HP (kW)			
Tier 4/Stage V	VOLVO TAD1384VE L6	510 HP (375 kW)	
Tier 2	VOLVO TAD1345VE L6	536 HP (394 kW)	
Max no load rpm		1.700 RPM	
Fuel tank capacity		840 L	222 gal
Fuel consumption			
Tier 4/Stage V		90 L/hr	24 gal/hr
Tier 2		100 L/hr	27 gal/hr
AD Blue/DEF consumption		3.6 L/hr	0.95 gal/h
Cooling rating		50°C ambient air	122°F ambient air
Air cleaner		Dry type, 2 stages with dual pre-cleaner	

CRAWLER DRIVE

	METRIC	US
Drive	Dual path, hydrostatic, planetary transmissions	
	Full counter rotation with double lever steering and double lever direction	
Infinitely variable speed	Forward and reverse	
Transfer mode driving	0 - 2.2 km/h	0 - 1.37 mph
Work mode driving	0 - 1.28 km/h	0 - 0.80 mph
Parking and service brake	Hydraulic due to lack of pressure	

DIGGING DRIVE

	METRIC	US
Drive	Hydrostatic, two pumps and two motors	
Flywheel gearboxes		
Digging speed ranges	0 - 192 m/min	0 - 630 fpm
	0 - 270 m/min	0 - 886 fpm
Digging wheel	Single wheel	
Cutters	Rotary carbide tipped	
Cutters shank diameter	2.5 - 3.8	1" - 1 1/2"
Cutters gage	6.4 cm	2 1/2"

TRACKS

	METRIC	US
Track chain type	B4	
Track length	442 cm	14' 6"
Space idler / sprocket	365 cm	12'
Track pad type	Triple grouser	
Track pad width	60 cm	2' 0"
Tilt Undercarriage	+/- 2.5°	

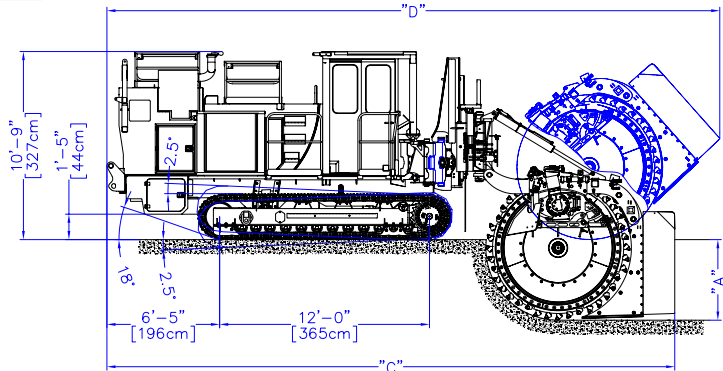
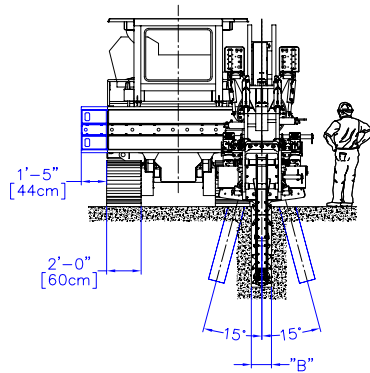

TOOL	"A"	"B"	"C"	"D"
R1200	3'-11" [120 cm]	Min 11" [28 cm] Max 18" [45 cm]	31'-7" [966 cm]	33'-7" [1027 cm]
R1200E	3'-11" [120 cm]	Min 7" [18 cm] Max 11" [28 cm]	31'-7" [966 cm]	33'-7" [1027 cm]
R1400	4'-7" [140 cm]	Min 11" [28 cm] Max 19" [48 cm]	32'-4" [987 cm]	35' [1066 cm]
R1400E	4'-7" [140 cm]	Min 7" [18 cm] Max 11" [28 cm]	32'-4" [987 cm]	35' [1066 cm]
R1600	5'-3" [160 cm]	Min 11" [28 cm] Max 20.4" [52 cm]	33'-3" [1014 cm]	35'-8" [1091 cm]

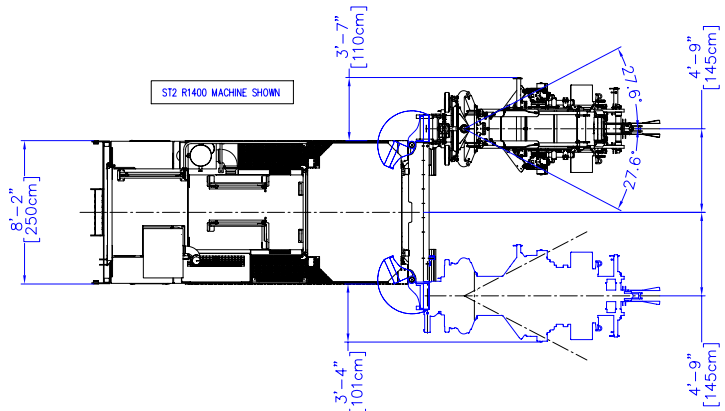

Rev. 11/24

Pictures & drawings can be different according to technical specifications - Updating programme variations without notice are possible

TESMEC
draw the way forward

www.tesmec.com