

# ST2 GD



Tesmec ST2 is a 25-27 metric ton-class trencher featuring a 510 HP (375 kW) Tier 4/Stage V engine, or a 536 HP (394 kW) Tier 3 engine, designed to allow the simultaneous trenching and mechanical laying for the deployment of networks in rural environments and rocky grounds

## STANDARD FEATURES

**Productivity** Exploit the productivity of ST2 GD with R1200, R1200E, R1400 and R1400E rocksaw attachments, featuring an hydraulic offset of 204 cm (6' 9") from center line on left and right, +/- 15° hydraulic tilt (rotation about horizontal axis) and +/- 27.6° hydraulic pivot (rotation about vertical axis). These are offered as standard with crumbshoe and security kit.

**Remote control** Experience the radio control system, which enables the operator to control the machine remotely, increasing the safety in site, the visibility on the trenching area and on the trenching tool.

## OPTIONAL FEATURES

- Set of 2 reel holder arms + Round bar : Ø60 mm Lg. 2700 mm
- Working light kit
- Accessories for mechanized laying
- Re.M
- Smart Tracker

## STATE OF THE ART TECHNOLOGY

**Re.M** The remote monitoring system with machine data remote monitoring, fleet location management, troubleshooting information and operating conditions

**Smart tracker** Automatically collects as-built data while the machine is trenching, avoiding survey stakeout and achieve the complete digitalization of the jobsite

## TRENCHING DIMENSIONS

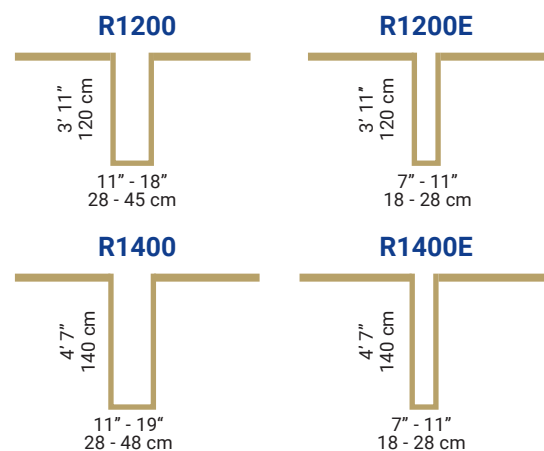

## TRANSPORT DIMENSIONS

		METRIC	US
<b>Length</b>	(R1200 - R1200E)	1065 cm	34' 11"
	(R1400 - R1400E)	1104 cm	36' 2"
<b>Width</b>		250 cm	8' 2"
<b>Height</b>		327 cm	10' 9"
<b>Weight</b>	(R1200)	26.340 Kg	58.000 lbs
	(R1200E)	25.190 Kg	55.500 lbs
	(R1400)	27.550 Kg	60.700 lbs
	(R1400E)	25.980 Kg	57.200 lbs
<b>Ground pressure</b>	(R1200)	0.66 kg/cm2	9.4 psi
	(R1200E)	0.63 kg/cm2	8.9 psi
	(R1400)	0.69 kg/cm2	10.1 psi
	(R1400E)	0.65 kg/cm2	9.4 psi

## ENGINE

		METRIC	US
<b>Model and Max HP (kW)</b>			
Tier 4/Stage V	VOLVO TAD1384VE L6	510 HP (375 kW)	
Tier 2	VOLVO TAD1345VE L6	536 HP (394 kW)	
<b>Max no load rpm</b>		1.700 RPM	
<b>Fuel tank capacity</b>		840 L	222 gal
<b>Fuel consumption</b>			
	Tier 4/Stage V	90 L/hr	24 gal/hr
	Tier 2	100 L/hr	27 gal/hr
<b>AD Blue/DEF consumption</b>		3.6 L/hr	0.95 gal/hr
<b>Cooling rating</b>		50°C ambient air	122°F ambient air
<b>Air cleaner</b>		Dry type, 2 stages with dual pre-cleaner	

## CRAWLER DRIVE

	METRIC	US
<b>Drive</b>	Dual path, hydrostatic, planetary transmissions	
	Full counter rotation with double lever steering and double lever direction	
<b>Infinitely variable speed</b>	Forward and reverse	
	Transfer mode driving	0 - 2.2 km/h      0 - 1.37 mph
	Work mode driving	0 - 1.28 km/h      0 - 0.80 mph
<b>Parking and service brake</b>	Hydraulic due to lack of pressure	

## DIGGING DRIVE

	METRIC	US
<b>Drive</b>	Hydrostatic, two pumps and two motors	
<b>Flywheel gearboxes</b>		
<b>Digging speed ranges</b>	0 - 192 m/min	0 - 630 fpm
	0 - 270 m/min	0 - 886 fpm
<b>Digging wheel</b>	Single wheel	
<b>Cutters</b>	Rotary carbide tipped	
<b>Cutters shank diameter</b>	2.5 - 3.8	1" - 1 1/2"
<b>Cutters gage</b>	6.4 cm	2 1/2"

## TRACKS

	METRIC	US
<b>Track chain type</b>	B4	
<b>Track length</b>	442 cm	14' 6"
<b>Space idler / sprocket</b>	365 cm	12'
<b>Track pad type</b>	Triple grouser	
<b>Track pad width</b>	60 cm	2' 0"
<b>Tilt Undercarriage</b>	+/- 2.5°	

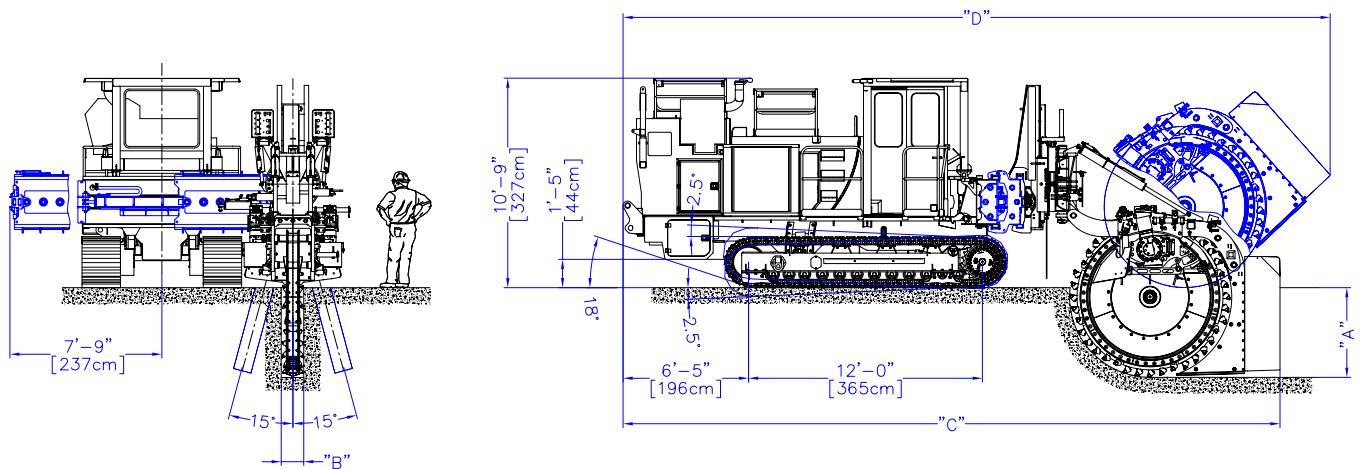

TOOL	"A"	"B"	"C"	"D"
R1200	3'-11" [120 cm]	Min 11" [28 cm] Max 18" [45 cm]	32'-11" [1004 cm]	34'-11" [1065 cm]
R1200E	3'-11" [120 cm]	Min 7" [18 cm] Max 11" [28 cm]	32'-11" [1004 cm]	34'-11" [1065 cm]
R1400	4'-7" [140 cm]	Min 11" [28 cm] Max 19" [48 cm]	33'-7" [1025 cm]	36'-2" [1104 cm]
R1400E	4'-7" [140 cm]	Min 7" [18 cm] Max 11" [28 cm]	33'-7" [1025 cm]	36'-2" [1104 cm]

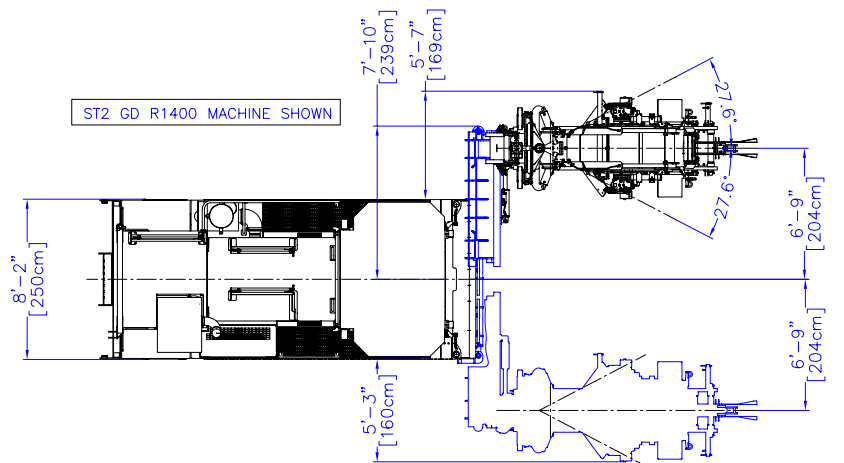

Rev. 11/24

Pictures & drawings can be different according to technical specifications - Updating programme variations without notice are possible

**TESMEC**  
draw the way forward

in YouTube Instagram Facebook  
www.tesmec.com